

# BLUE STAR

## Power Systems Inc.

Diesel Product Line

208-600 Volt

PD300-01

60 Hz / 1800 RPM

300 kWe

Standby

### Ratings

	208V	240V	480V	600V
<b>Phase</b>	3	3	3	3
<b>PF</b>	0.8	0.8	0.8	0.8
<b>Hz</b>	60	60	60	60
<b>Generator Model</b>	S4L1D-E41	S4L1D-E41	S4L1D-D41	S4L1S-D4
<b>Connection</b>	12 LEAD WYE	12 LEAD DELTA	12 LEAD WYE	4 LEAD WYE
<b>kWe</b>	300	300	300	300
<b>AMPS</b>	1042	903	452	361
<b>Temp Rise</b>	125°C / 40°C	125°C / 40°C	125°C / 40°C	125°C / 40°C

### Standard Equipment

#### Engine

- Radiator Cooled Unit Mounted (50°C)
- Radiator Duct Flange (OPU Only)
- Blower Fan & Fan Drive
- Starter & Alternator
- Oil Pump & Filter
- Oil Drain Extension w/Valve
- Governor - Electronic Isochronous
- 24V Battery System & Cables
- Air Cleaner (Dry Single Stage)
- Critical Grade Silencer Mounted
- Flexible Fuel Connector
- EPA Certified Tier 3

#### Generator

- Brushless Single Bearing
- Automatic Voltage Regulator
- ± 0.50% Voltage Regulation
- 4 Pole, Rotating Field
- 125°C Standby Temperature Rise
- 100% of Rated Load - One Step
- 5% Maximum Harmonic Content
- NEMA MG 1, IEEE and ANSI Standards Compliance for Temperature Rise

#### Additional

- Single Source Supplier
- UL 2200 & cUL Listed
- CSA Certified
- Seismic Certified to IBC 2021
- NFPA 110 / CSA C282 Compliant
- Microprocessor Based Digital Control Panel Mounted in NEMA 12 Enclosure
- Base - Formed Steel
- Main Line Circuit Breaker Mounted & Wired
- Battery Charger 24V 5 Amp
- Jacket Water Heater -20°F 2500W 240V w/Isolation Valves
- Vibration Isolation Mounts
- 2 Year / 2000 Hour Standby Warranty
- Standard Colors - White / Gray

### Application Data

#### Engine

Manufacturer:	Perkins	Displacement - Cu. In. (lit):	568 (9.30)
Model:	1706D-E93TAG2	Bore - in. (cm) x Stroke - in. (cm):	4.53 (11.5) x 5.87 (14.9)
Type:	4-Cycle	Compression Ratio:	16.5:1
Aspiration:	Turbo Charged, CAC	Rated RPM:	1800
Cylinder Arrangement:	6 Cylinder Inline	Max HP Stby (kWm):	475 (354)

#### Exhaust System

#### Standby

Gas Temp. (Stack): °F (°C)	959 (515)
Gas Volume at Stack Temp: CFM (m³/min)	2,435 (68.9)
Maximum Allowable Exhaust Restriction: in. H <sub>2</sub> O (kPa)	40.0 (10.0)

#### Cooling System

Ambient Capacity of Radiator: °F (°C)	122 (50.0)
Maximum Allowable Static Pressure on Rad. Exhaust: in. H <sub>2</sub> O (kPa)	0.50 (0.12)
Water Pump Flow Rate: GPM (lit/min)	87.2 (330)
Heat Rejection to Coolant: BTUM (kW)	7,771 (136)
Heat Rejection to CAC: BTUM (kW)	6,057 (106)
Heat Radiated to Ambient: BTUM (kW)	6,066 (106)

#### Air Requirements

Aspirating: CFM (m³/min)	951 (26.9)
Air Flow Required for Rad. Cooled Unit: CFM (m³/min)	17,032 (482)
Air Flow Required for Heat Exchanger/Rem. Rad. CFM (m³/min)	Consult Factory For Remote Cooled Applications

#### Fuel Consumption

At 100% of Power Rating: gal/hr (lit/hr)	22.3 (84.3)
At 75% of Power Rating: gal/hr (lit/hr)	17.2 (65.1)
At 50% of Power Rating: gal/hr (lit/hr)	12.6 (47.9)

#### Fluids Capacity

Total Oil System: gal (lit)	7.93 (30.0)
Engine Jacket Water Capacity: gal (lit)	5.36 (20.3)
System Coolant Capacity: gal (lit)	9.46 (35.8)

Deration Factors: Rated Power is available up to 3281ft (1000m) at ambient temperatures to 104°F (40°C). Consult factory for site conditions above these parameters.

## DCP7310 Control Panel

### Standard Features

- Digital Metering
- Engine Parameters
- Generator Protection Functions
- Engine Protection
- CAN Bus (J1939) ECU Communications
- Windows-Based Software
- Multilingual Capability
- Remote Communications to DSE2548 Remote Annunciator
- 8 Programmable Contact Inputs
- 10 Contact Outputs
- RS485 Communicator Interface
- cULus Listed, CE Approved
- Event Recording
- IP 65 rating (with supplied gasket) offers increased resistance to water ingress
- NFPA 110 Level 1 Compatible



## Weights / Dimensions / Sound Data

	L x W x H	Weight lbs
<b>OPU</b>	120 x 66 x 78 in	6,050
<b>Level 1</b>	156 x 66 x 94 in	7,300
<b>Level 2</b>	156 x 66 x 94 in	7,375
<b>Level 3</b>	196 x 66 x 94 in	7,700

Please allow 6-12 inches for height of exhaust stack.

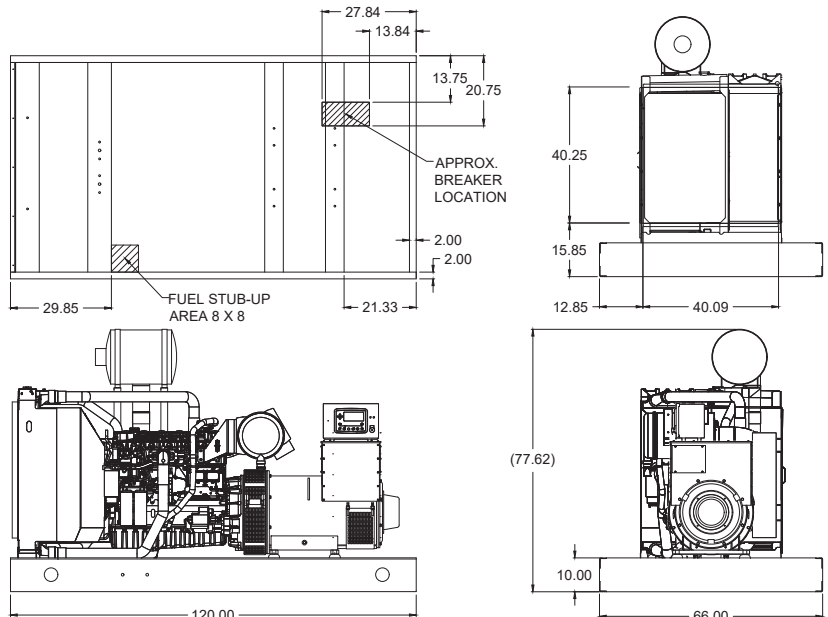

	No Load	Full Load
<b>OPU</b>	86 dBA	88 dBA
<b>Level 1</b>	83 dBA	85 dBA
<b>Level 2</b>	77 dBA	79 dBA
<b>Level 3</b>	69 dBA	71 dBA

## Enclosures & Fuel Tanks

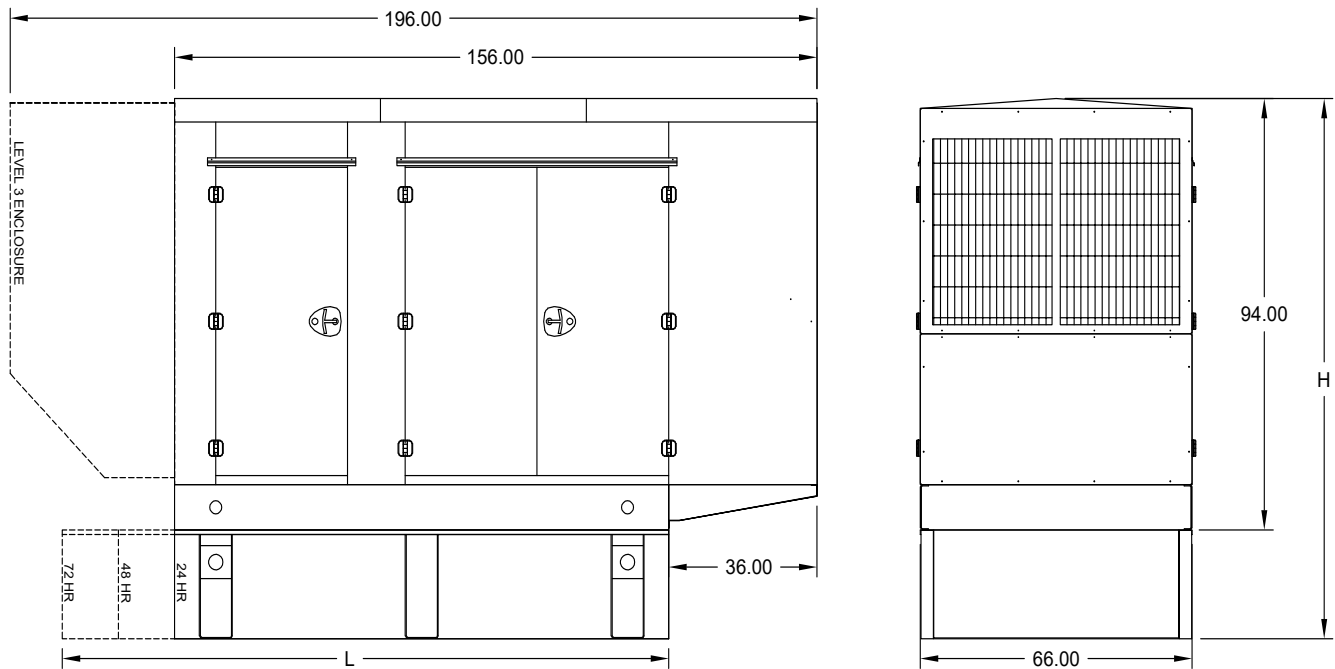

- All enclosure models are 200 MPH wind rating certified in accordance with IBC2021 and ASCE/SEI 7-16 standards.
- Level 2 & 3 enclosures include sound attenuation foam
- Level 3 enclosure includes frontal sound & exhaust hood.
- Enclosure height does not include exhaust stack.

	24 Hour 540 Gallon	48 Hour 1080 Gallon	72 Hour 1620 Gallon
<b>L</b>	120.00	162.00	228.00
<b>H</b>	118.00	130.00	130.00

### Notes

- All specification sheet dimensions are represented in inches.
- All drawings based on standard 480 volt standby generator. Lengths may vary with other voltages. All drawings and dimensions subject to change without notice.
- All enclosures and fuel tanks are based on the standard unit configuration. Any requested deviation can change dimensions.
- Sound data is measured at 23 feet (7 meters) in accordance with ISO 8528-10.
- All materials and specifications subject to change without notice.

American Owned



American Made

**Blue Star Power Systems, Inc.**

2250 Carlson Drive

North Mankato, Minnesota 56003

Phone + 1 507 345 1776

bluestarps.com

quote.bluestarps.com

sales@bluestarps.com