

48HR TANK
TD550-01, TD600-01
VD600-01
PD550-01, PD600-01
LV0 / LV1 / LV2 / LV3

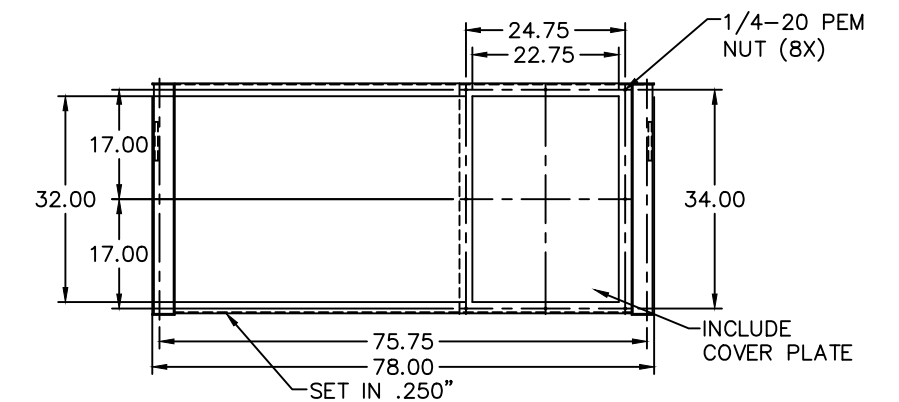
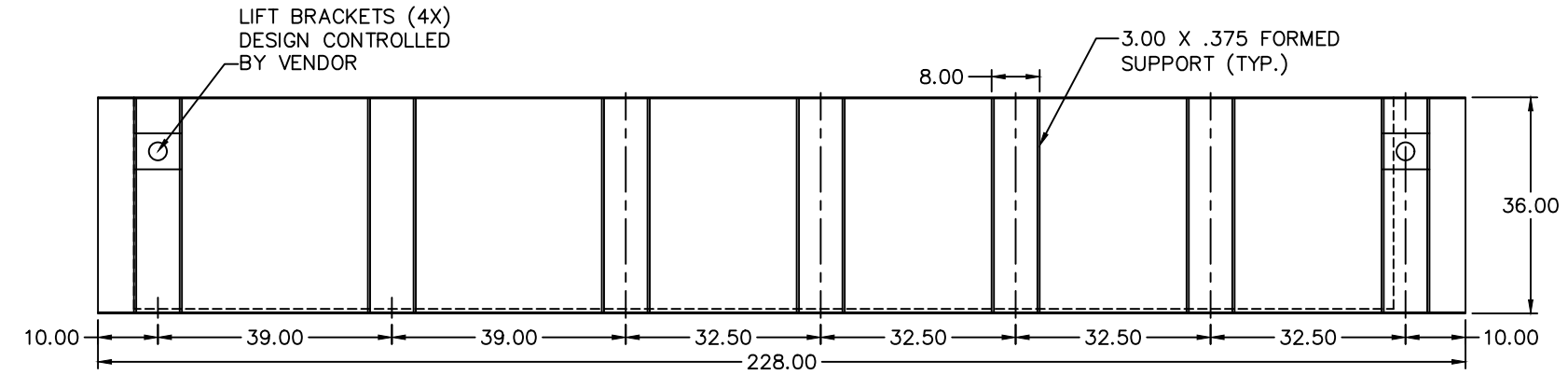
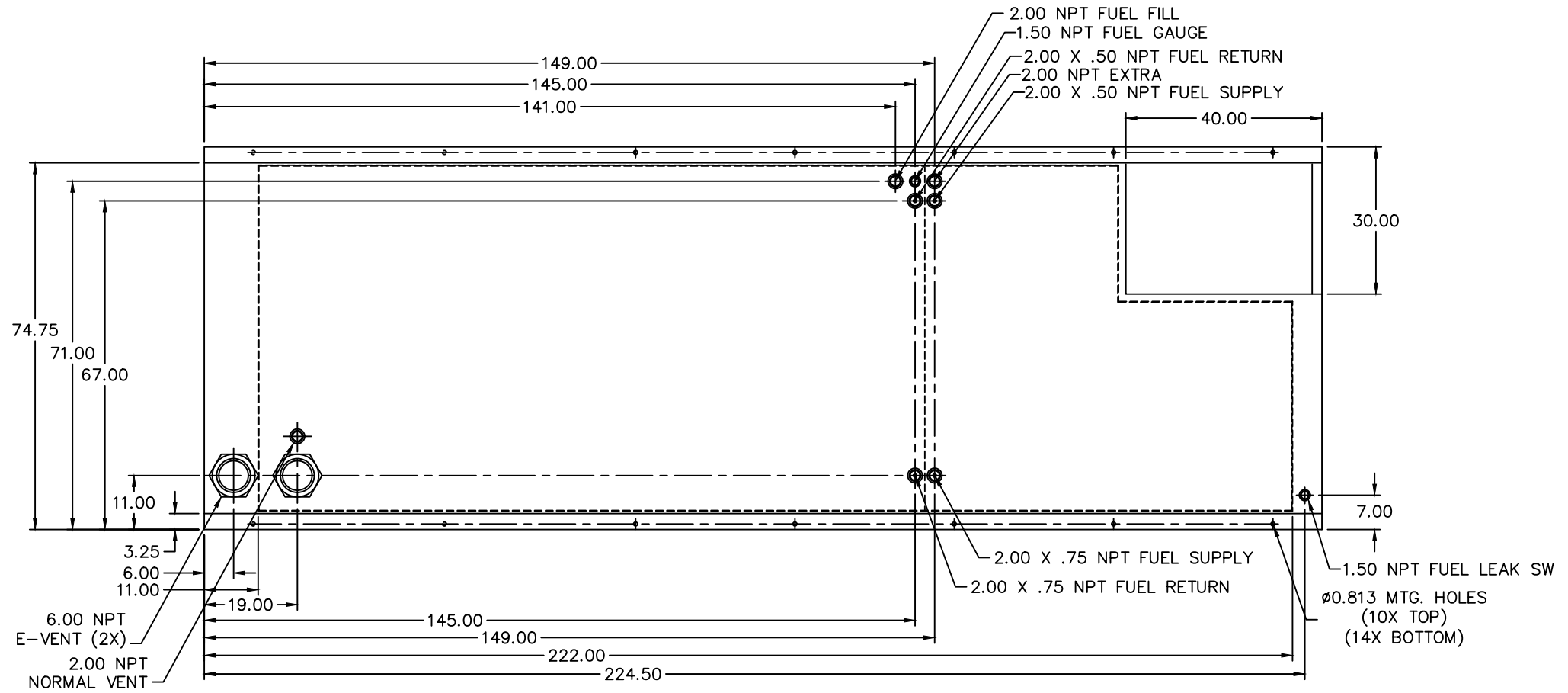

APPROXIMATE WEIGHT: 5400LBS

- NOTES:
1. MATERIAL: 7GA. RUPTURE BASIN
10GA. INNER TANK
 2. SECONDARY CONTAINMENT TANK
 3. FINISH PAINT BLACK HAMMERED
 4. TANK TO INCLUDE
 - FUEL SUPPLY / RETURN DIP TUBES
 - LIFTING / TIE DOWN BRACKETS

REVISIONS:			
LEVEL:	DESCRIPTION:	DATE:	BY:
05	CHANGED 2ND SET OF SUPPLY/RETURN TO 2.00 X .75 NPT	03-10-21	MGH
04	ADDED ULC TO TANK DESCRIPTION	01-21-20	MGH
03	MOVE MOUNTING HOLES, EXPAND STUB-UP	05-24-19	ATB
02	MOVED VENTS TO FRONT, TANK MATERIAL	10-10-17	KAP
01	ADJUSTED FOR TD550, TD600 & VD600	12-30-15	KDH

BLUE STAR
Power Systems Inc.

TANK SB 2000GL DW UL/ULC W/STUB-UP		
P/N: 19426	228"L X 78"W X 36"H	
DATE: 12-03-15	BY: KAP	DRAWN TO SCALE