

**24HR TANK
VD100
JD80, JD100, JD125
LV0/LV1/LV2/LV3**

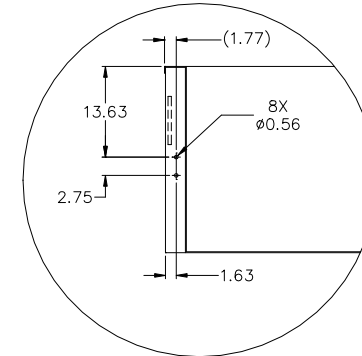

STEP HOLE DETAIL

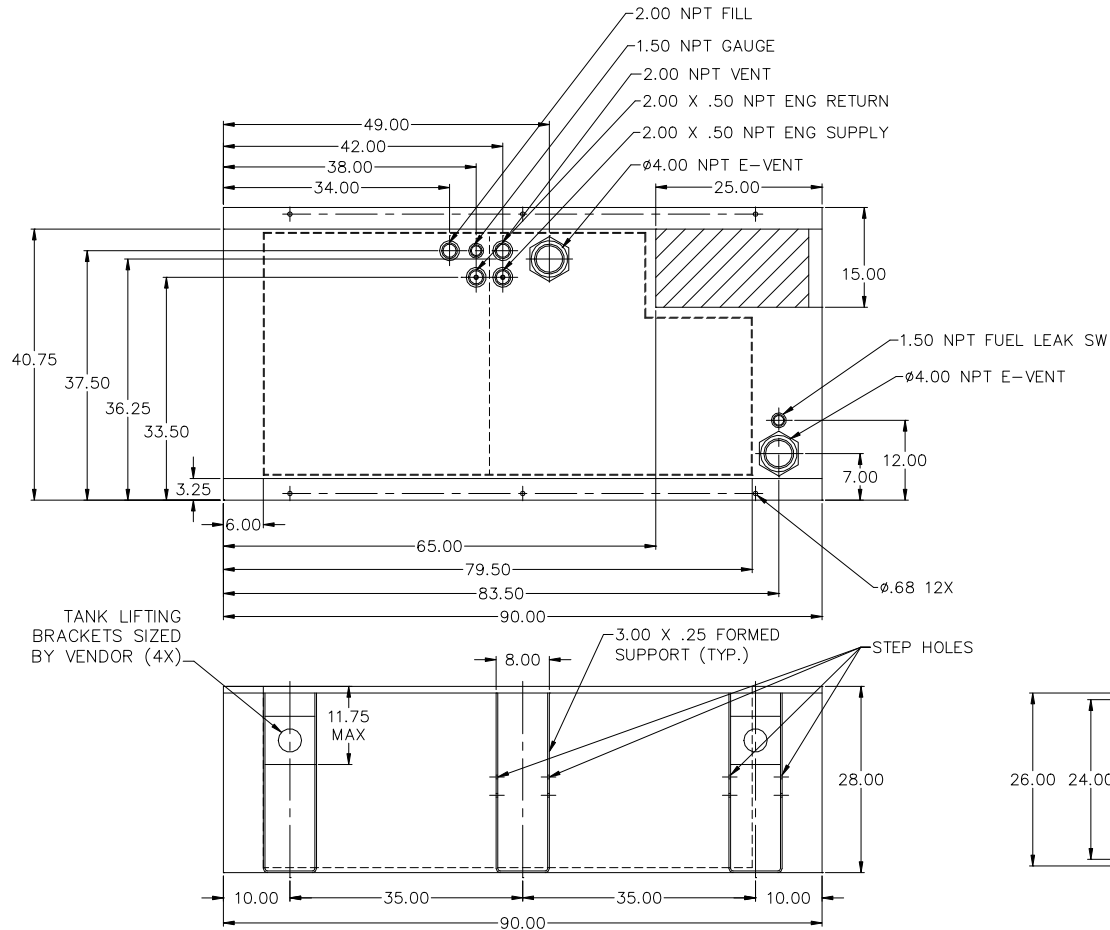
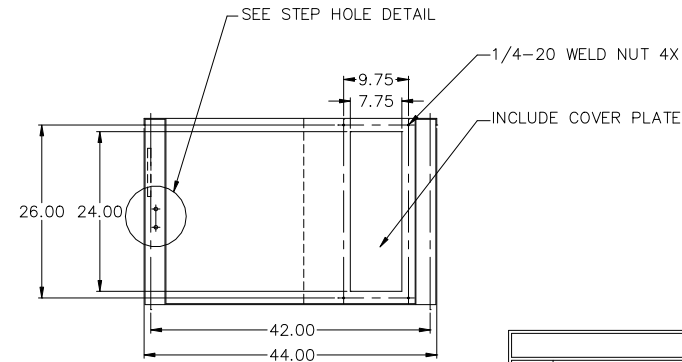

NOTES:

1. MATERIAL: 10GA
2. SECONDARY CONTAINMENT TANK
3. FINISH: [POWDER COAT BLACK-HAMMERED]
4. TANK TO INCLUDE
 - FUEL SUPPLY / RETURN DIP TUBES
 - LIFTING / TIE DOWN BRACKETS

APPROXIMATE WEIGHT: 1200 LBS

REVISIONS:

LEVEL	DESCRIPTION:	DATE:	BY:
02	CHANGE FINISH TO POWDER BLACK-HAMMERED	01-22-16	KAP
01	MOVED VENTS AND FILLS FOR OIL DRAIN	01-08-16	KDH

BLUE STAR
Power Systems Inc.

TANK SB 250GL DW UL W/STUB-UP

P/N: 17961 90"L X 44"W X 28"H

DATE: 11-20-15

BY: TDH

DRAWN TO SCALE