

72HR TANK
JD80, JD100, JD125
VD100 (01)

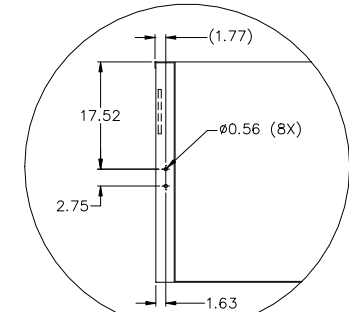

TANK LIFTING
 BRACKETS SIZED
 BY VENDOR (4X)

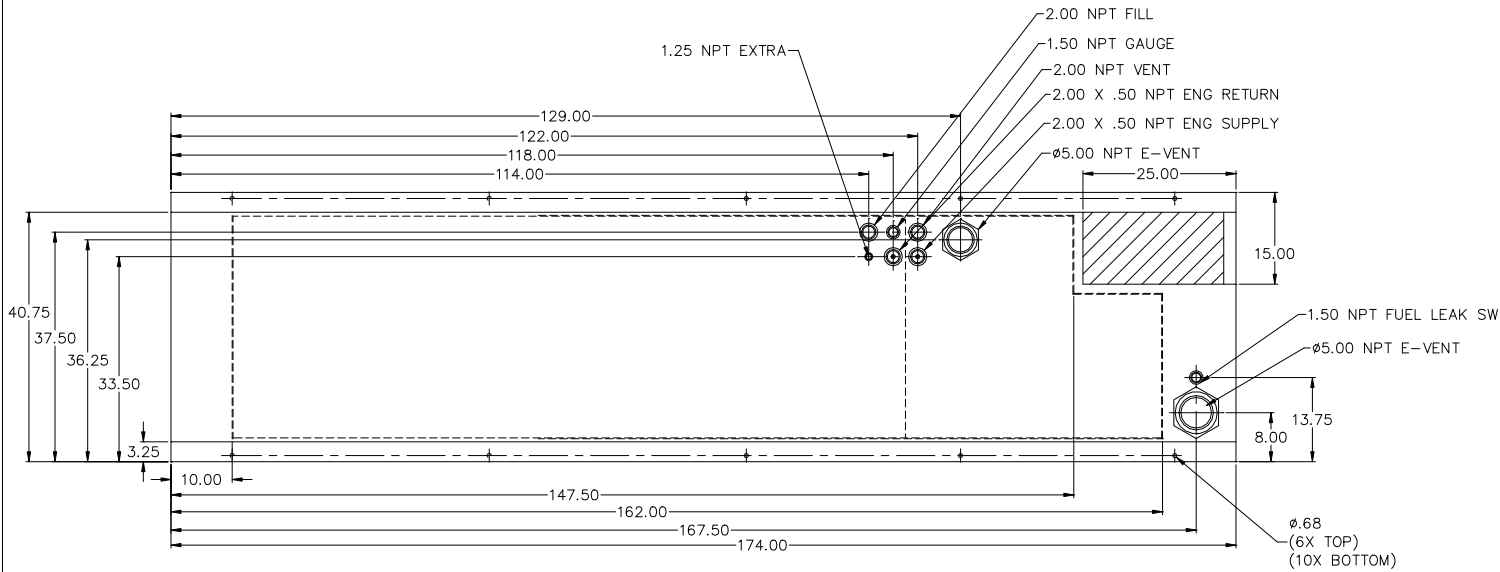
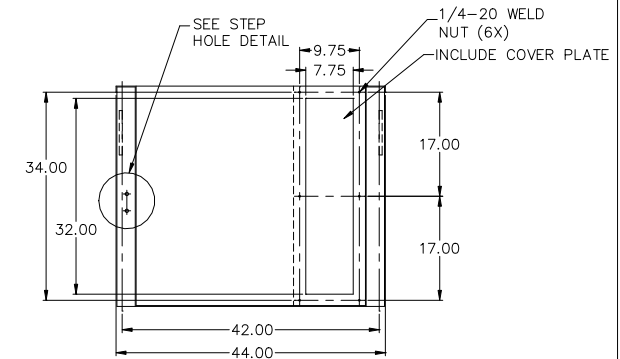
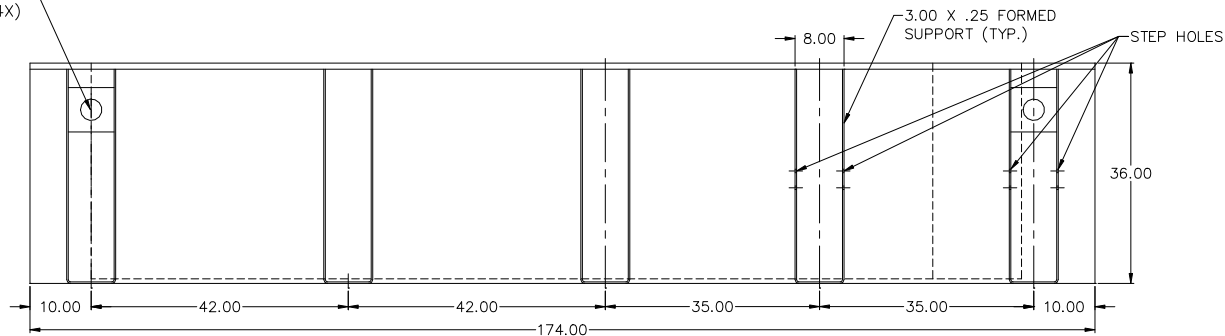

APPROXIMATE WEIGHT: 2200 LBS

NOTES:

1. MATERIAL: 10GA
2. SECONDARY CONTAINMENT TANK
3. FINISH PAINT SEMI GLOSS BLACK
4. TANK TO INCLUDE
 - FUEL SUPPLY / RETURN DIP TUBES
 - LIFTING / TIE DOWN BRACKETS

BLUE STAR
 Power Systems Inc.

TANK SB 750GL DW UL W/STUB-UP

P/N: NA 174"L X 44"W X 36"H

DATE: 12-21-15

BY: KDH

DRAWN TO SCALE