

# BLUE STAR

## Power Systems Inc.

Diesel Product Line

208-600 Volt

PD100-01

60 Hz / 1800 RPM

100 kWe

Standby

### Ratings

	240V	208V	240V	480V	600V
<b>Phase</b>	1	3	3	3	3
<b>PF</b>	1.0	0.8	0.8	0.8	0.8
<b>Hz</b>	60	60	60	60	60
<b>Generator Model</b>	363PSL3133	362CSL1606	362CSL1606	362CSL1606	362PSL1636
<b>Connection</b>	12 LEAD ZIG-ZAG	12 LEAD WYE	12 LEAD DELTA	12 LEAD WYE	4 LEAD WYE
<b>Standby</b>					
<b>kWe</b>	100	100	100	100	100
<b>AMPS</b>	417	347	301	151	120
<b>Temp Rise</b>	130°C / 27°C	130°C / 27°C	130°C / 27°C	130°C / 27°C	130°C / 27°C

### Standard Equipment

- |  |  |  |
|--|--|--|
| <p><b>Engine</b></p> <ul style="list-style-type: none"> <li>▶ Radiator Cooled Unit Mounted (50°C)</li> <li>▶ Blower Fan &amp; Fan Drive</li> <li>▶ Starter &amp; Alternator</li> <li>▶ Oil Pump &amp; Filter</li> <li>▶ Oil Drain Extension w/Valve</li> <li>▶ Governor - Electronic Isochronous</li> <li>▶ 12V Battery System &amp; Cables</li> <li>▶ Air Cleaner (Dry Single Stage)</li> <li>▶ Flexible Fuel Connector</li> <li>▶ EPA Certified Tier 3</li> </ul> <p><b>Listing Certifications</b></p> <ul style="list-style-type: none"> <li>▶ UL 2200 Listed</li> <li>▶ cUL Listed</li> <li>▶ CSA Certified</li> <li>▶ Seismic Certified to IBC 2018</li> <li>▶ NFPA110 Compliant</li> </ul> | <p><b>Generator</b></p> <ul style="list-style-type: none"> <li>▶ Brushless Single Bearing</li> <li>▶ Automatic Voltage Regulator</li> <li>▶ ± 1% Voltage Regulation</li> <li>▶ 4 Pole, Rotating Field</li> <li>▶ 130°C Standby Temperature Rise</li> <li>▶ 100% of Rated Load - One Step</li> <li>▶ 5% Maximum Harmonic Content</li> <li>▶ NEMA MG 1, IEEE and ANSI Standards Compliance for Temperature Rise</li> </ul> | <p><b>Additional</b></p> <ul style="list-style-type: none"> <li>▶ Microprocessor Based Digital Control</li> <li>▶ Interface Connection Box</li> <li>▶ Control Panel Mounted in NEMA 12 Enclosure</li> <li>▶ Base - Formed Steel</li> <li>▶ Main Line Circuit Breaker Mounted &amp; Wired</li> <li>▶ Critical Grade Silencer Mounted</li> <li>▶ Battery Charger 12V 6 Amp</li> <li>▶ Jacket Water Heater -20°F 1500W 120V w/Isolation Valves</li> <li>▶ Vibration Isolation Mounts</li> <li>▶ Radiator Duct Flange (OPU Only)</li> <li>▶ Single Source Supplier</li> <li>▶ 2YR / 2000HR Standby Warranty</li> <li>▶ Standard Colors - White / Tan / Gray</li> </ul> |
|--|--|--|

## Application Data

Engine			
Manufacturer:	Perkins	Displacement - Cu. In. (lit):	269 (4.40)
Model:	1104D-E44TAG2	Bore - in. (cm) x Stroke - in. (cm):	4.13 (10.5) x 5.00 (12.7)
Type:	4-Cycle	Compression Ratio:	16.7:1
Aspiration:	Turbocharged, CAC	Rated RPM:	1800
Cylinder Arrangement:	4 Cylinder Inline	Max HP Stby (kWm):	161 (120)

Exhaust System	Standby
Gas Temp. (Stack): °F (°C)	1,218 (659)
Gas Volume at Stack Temp: CFM (m³/min)	714 (20.2)
Maximum Allowable Exhaust Restriction: in. H <sub>2</sub> O (kPa)	60.0 (15.0)

Cooling System	
Ambient Capacity of Radiator: °F (°C)	122 (50.0)
Maximum Allowable Static Pressure on Rad. Exhaust: in. H <sub>2</sub> O (kPa)	0.50 (0.12)
Water Pump Flow Rate: GPM (lit/min)	44.9 (170)
Heat Rejection to Coolant: BTUM (kW)	3,137 (54.9)
Heat Rejection to CAC: BTUM (kW)	1,034 (18.1)
Heat Radiated to Ambient: BTUM (kW)	1,138 (19.9)

Air Requirements	
Aspirating: CFM (m³/min)	312 (8.82)
Air Flow Required for Rad. Cooled Unit: CFM (m³/min)	7,703 (218)
Air Flow Required for Heat Exchanger/Rem. Rad. CFM (m³/min)	Consult Factory For Remote Cooled Applications

Fuel Consumption	
At 100% of Power Rating: gal/hr (lit/hr)	7.90 (29.9)
At 75% of Power Rating: gal/hr (lit/hr)	5.86 (22.2)
At 50% of Power Rating: gal/hr (lit/hr)	4.20 (15.9)

Fluids Capacity	
Total Oil System: gal (lit)	2.22 (8.40)
Engine Jacket Water Capacity: gal (lit)	1.85 (7.00)
System Coolant Capacity: gal (lit)	4.49 (17.0)

### Deration Factors

Rated Power Available up to 9800ft (3000m) at ambient temperatures to 122°F (50°C).  
Consult factory for site conditions above these parameters.

### DGC-2020 Control Panel

#### Standard Features

- ▶ Digital Metering
- ▶ Engine Parameters
- ▶ Generator Protection Functions
- ▶ Engine Protection
- ▶ CAN Bus ECU Communications
- ▶ Windows-Based Software
- ▶ Multilingual Capability
- ▶ Remote Communications to RDP-110 Remote Annunciator
- ▶ 16 Programmable Contact Inputs
- ▶ Up to 15 Contact Outputs (7 standard)
- ▶ UL Recognized, CSA Certified, CE Approved
- ▶ Event Recording
- ▶ IP 54 Front Panel Rating with Integrated Gasket
- ▶ NFPA 110 Level 1 Compatible

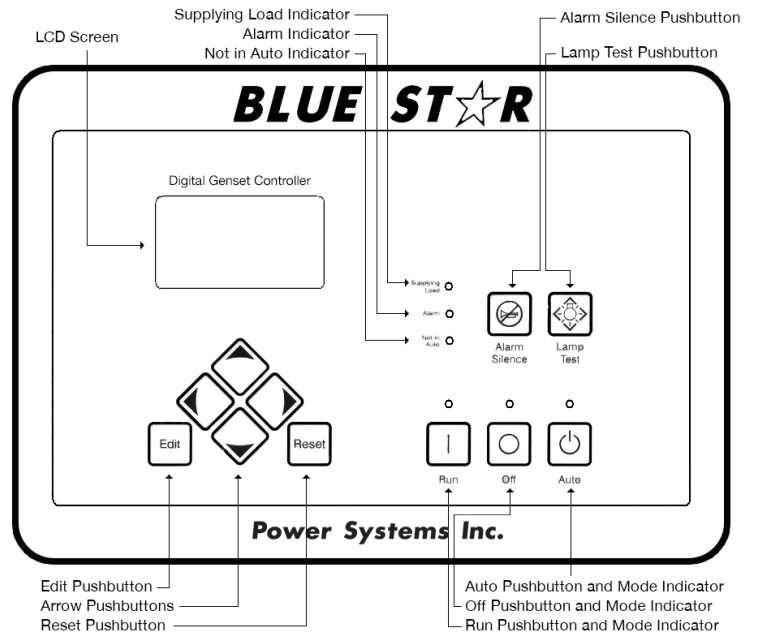

### Weights / Dimensions / Sound Data

	L x W x H	Weight lbs
<b>OPU</b>	90 x 44 x 60 in	2,250
<b>Level 1</b>	102 x 44 x 74 in	2,875
<b>Level 2</b>	102 x 44 x 74 in	2,925
<b>Level 3</b>	132 x 44 x 66 in	3,050

Please allow 6-12 inches for height of exhaust stack.

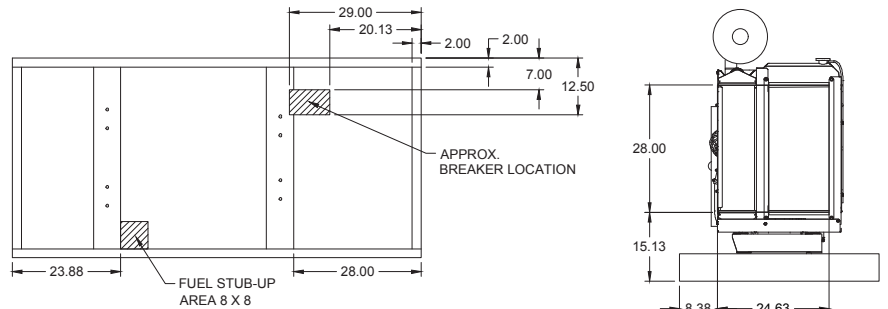

	No Load	Full Load
<b>OPU</b>	78 dBA	82 dBA
<b>Level 1</b>	75 dBA	78 dBA
<b>Level 2</b>	72 dBA	74 dBA
<b>Level 3</b>	66 dBA	68 dBA

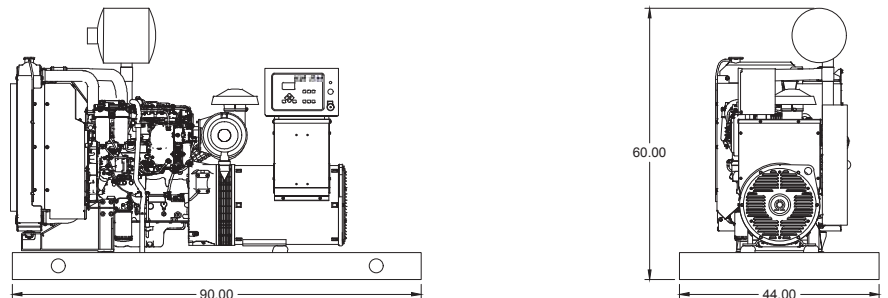

Drawings based on standard open power 480 volt standby generator. Lengths may vary with other voltages. Subject to change without notice. Sound data as measured at 23 feet (7 meters) in accordance with ISO 8528-10 at standby rating.

## Enclosures

Level 1 & 2 | Side View (Weather Proof)

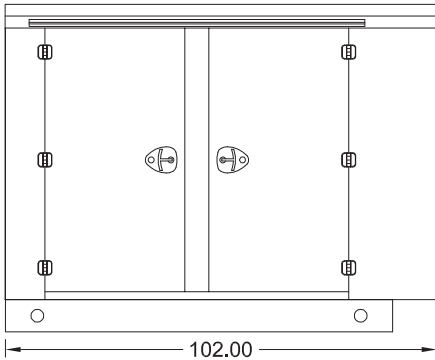

Level 3 | Side View (Sound Attenuated)

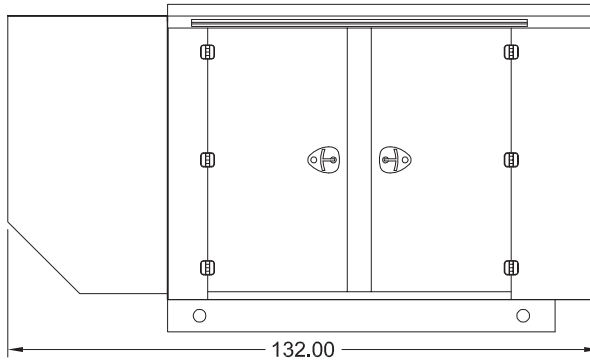

Level 1, 2 & 3 | Intake View

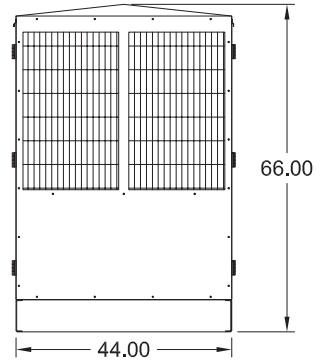

All enclosures are 150 MPH Wind Rated.

Level 2 & 3 enclosures include sound attenuation foam.

Level 3 enclosure includes frontal sound & exhaust hood.

\*Enclosure height does not include exhaust stack.

## Double Wall UL 142 Listed Fuel Tanks

Side View

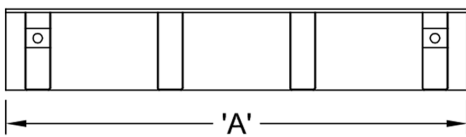

Rear View

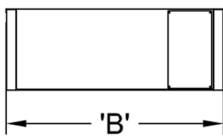

	24 Hour 250 Gallon	48 Hour 500 Gallon	72 Hour 750 Gallon
<b>A</b>	90.00	120.00	174.00
<b>B</b>	44.00	44.00	44.00
<b>C</b>	28.00	36.00	36.00

All specification sheet dimensions are represented in inches.

All enclosures and fuel tanks are based on the standard standby unit configuration. Any deviation can change dimensions.

Materials and specifications subject to change without notice.

American Owned



American Made

Distributed By:

**Blue Star Power Systems, Inc.**

52146 Ember Road

Lake Crystal, Minnesota 56055

Phone + 1 507 726 2508

bluestarps.com

quote.bluestarps.com

sales@bluestarps.com