

48HR TANK
JD150, JD200
VD150, VD200 (01)
PD125, PD150, PD180, PD200
LV0/LV1/LV2/LV3

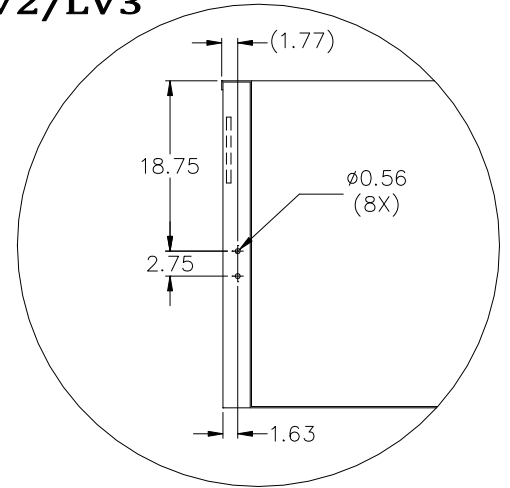

TANK LIFTING BRACKETS SIZED BY VENDOR (4X)

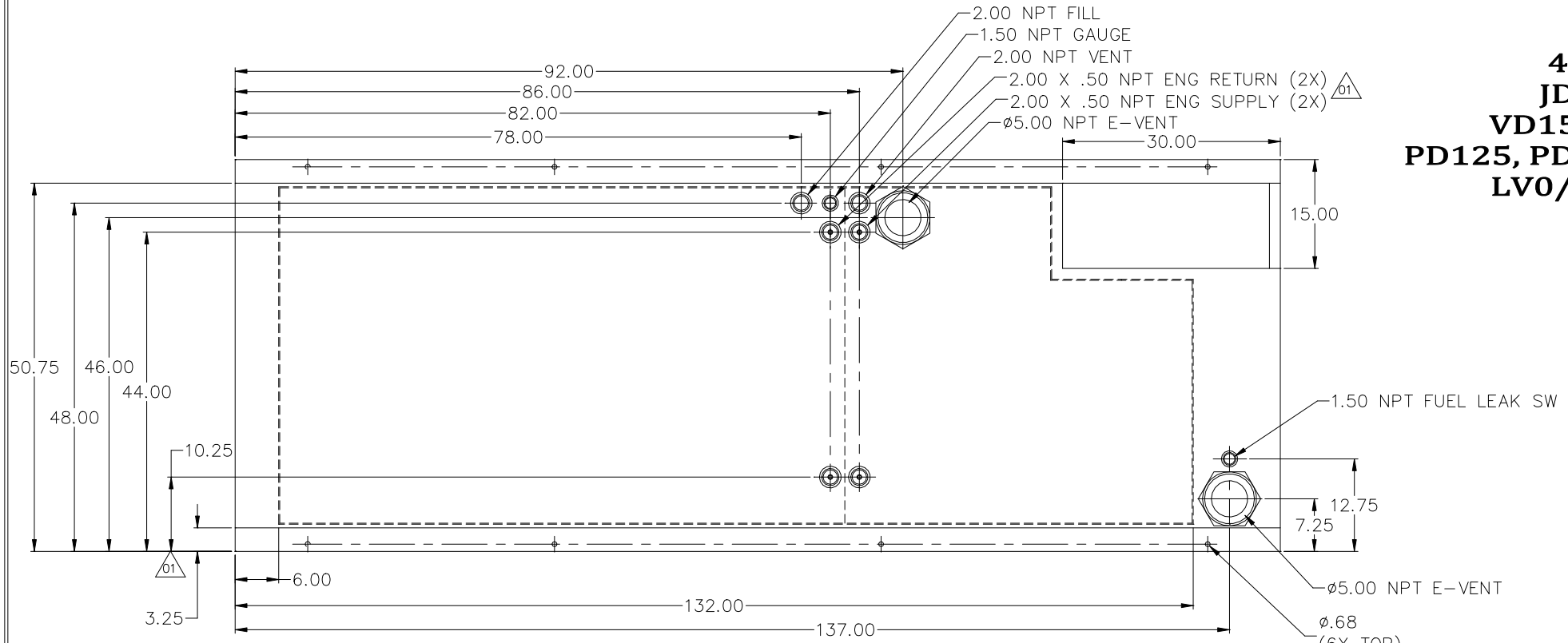
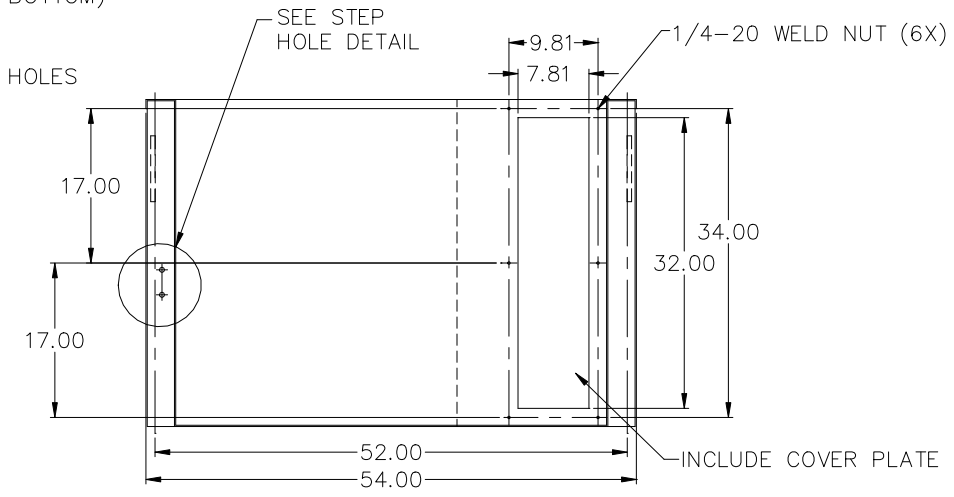
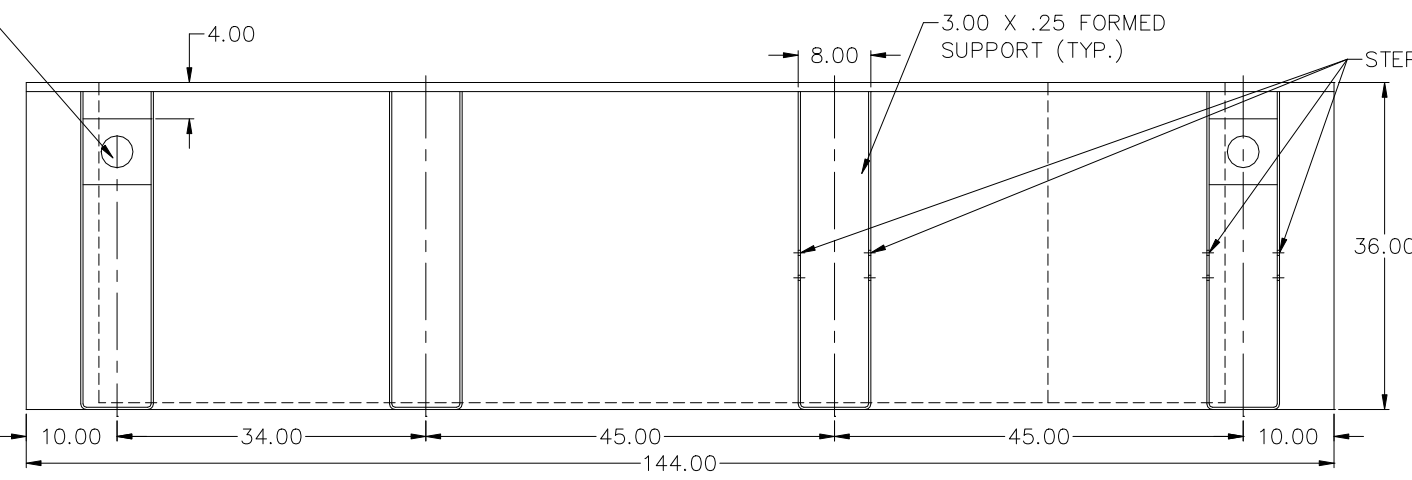

APPROXIMATE WEIGHT: 2200 LBS

- NOTES:
1. MATERIAL: 10GA
 2. SECONDARY CONTAINMENT TANK
 3. FINISH PAINT GLOSS BLACK
 4. TANK TO INCLUDE
 - FUEL SUPPLY / RETURN DIP TUBES
 - LIFTING / TIE DOWN BRACKETS



TANK SB 750GL DW UL W/STUB-UP

P/N: 20098	144"L X 54"W X 36"H
DATE: 12-18-15	BY: KDH
	DRAWN TO SCALE

REVISIONS:			
LEVEL:	DESCRIPTION:	DATE:	BY:
01	ADDED SECOND SUPPLY AND RETURN FOR PD ENGINES	6-6-18	TDH