

48HR / 1,800GL FUEL TANK
 VD450-01, VD500-01
 LV0 / LV1 / LV2 / LV3

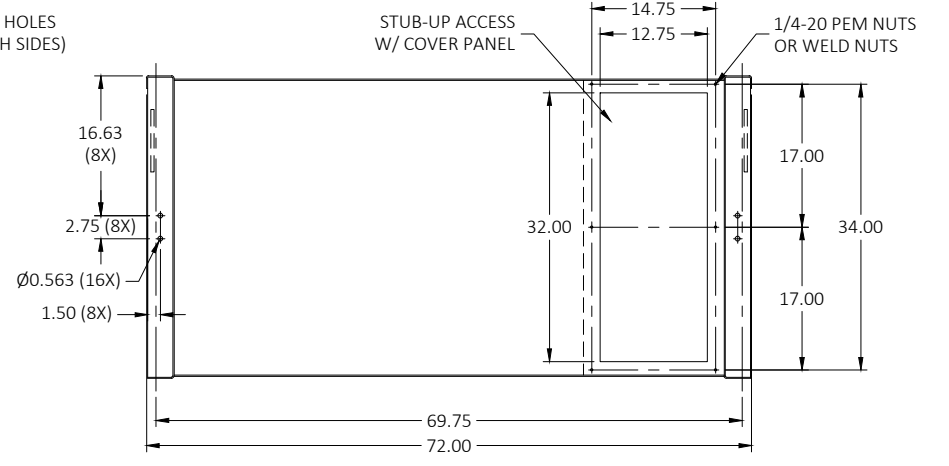
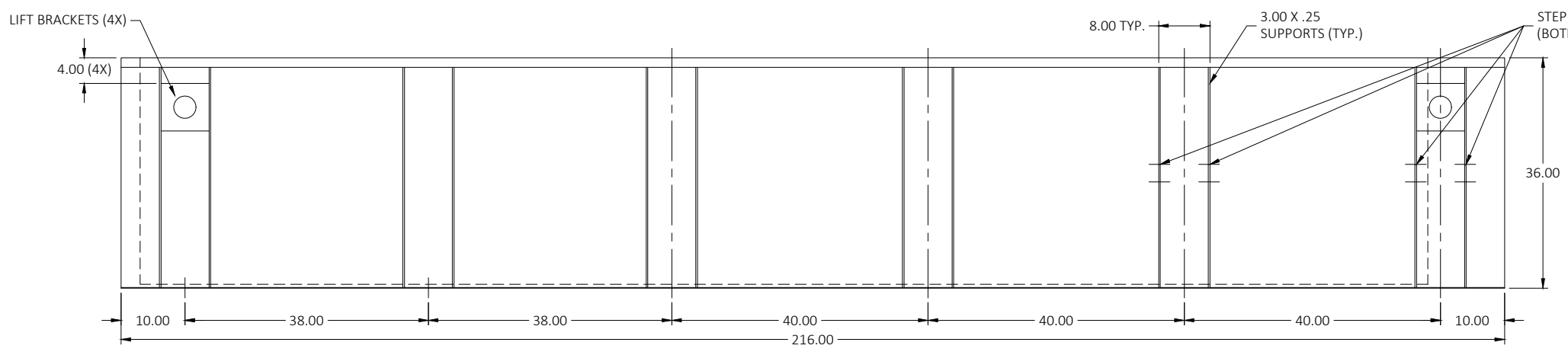
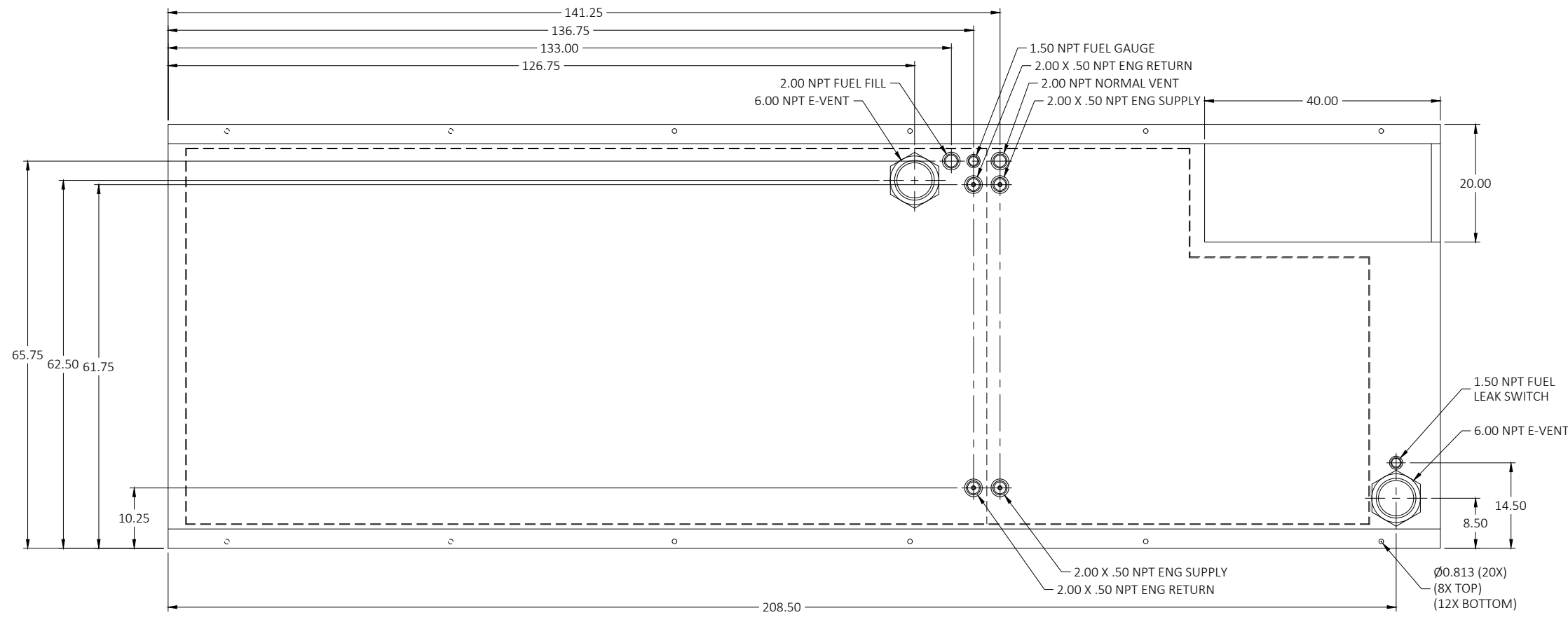

- NOTES:
- MATERIAL: PER UL/ULC REQUIREMENTS
 - SECONDARY CONTAINMENT TANK
 - TANK TO INCLUDE:
 - FUEL SUPPLY/RETURN DIP TUBES
 - LIFTING/TIE-DOWN BRACKETS

MATERIAL: SEE NOTES FINISH: BLACK HAMMERED

LEVEL:		DESCRIPTION:		DATE:	BY:
REVISIONS:					
<small>THE INFORMATION CONTAINED IN THIS DRAWING IS THE SOLE PROPERTY OF BLUE STAR POWER SYSTEMS, INC. ANY REPRODUCTION, IN PART OR AS A WHOLE, WITHOUT THE WRITTEN PERMISSION IS PROHIBITED.</small>					
<h1 style="margin: 0;">BLUE STAR</h1> <h2 style="margin: 0;">Power Systems Inc.</h2> <small>2250 CARLSON DRIVE, NORTH MANKATO, MINNESOTA 56003 1 507 345 1776</small>					
<h3 style="margin: 0;">TANK SB 1800GL DW SC UL/ULC W/ STUB-UP</h3>					
DIMENSIONS ARE IN INCHES		DRAWN BY: CRC	DATE: 12-09-22	SIZE: B	PART NUMBER: 20789
DO NOT SCALE DRAWING		APPROVED: CRC	DATE: 12-09-22	SCALE: NONE	APPROX. WEIGHT: 4,500 LBS